

593(FAST & DUAL)

573(SINGLE)

335

238

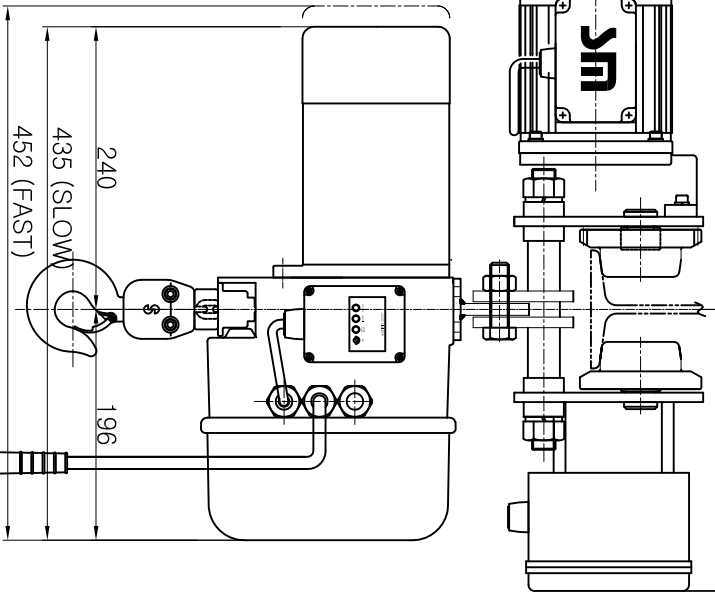

452

130

323

193

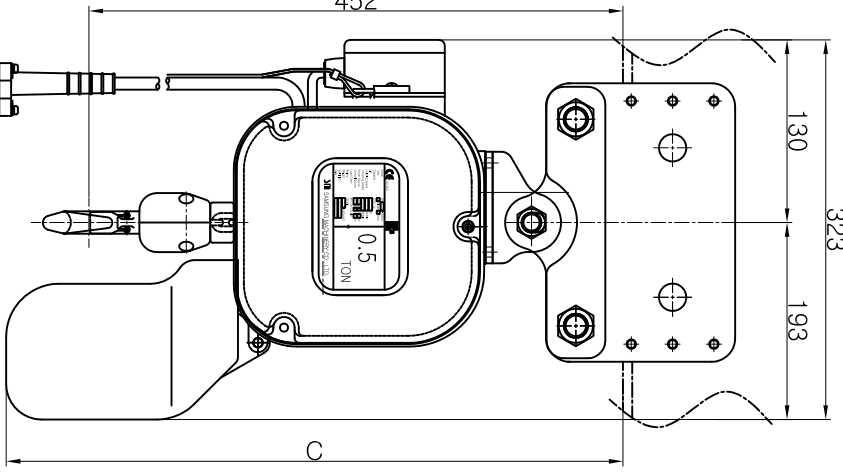

SPECIFICATION

HOISTING LOAD	0.5 TON	
TESTING LOAD	0.62 TON	
LIFTING HEIGHT	Min. 3 M ~ Max 50 M	
HOISTING	FAST	SPEED 8.4 M/MIN MOTOR 1.1 Kw x 4 P
	SLOW	SPEED 5.6 M/MIN MOTOR 0.65 Kw x 4 P
	DUAL	SPEED 5.6 / 1.8 M/MIN MOTOR 0.7 / 0.23 Kw x 4/12 P
TRAVERSING	FAST	SPEED 20.0 M/MIN MOTOR 0.4 Kw x 4 P
	MIDDLE	SPEED 13.3 M/MIN MOTOR 0.3 Kw x 6 P
	SLOW	SPEED 10.0 M/MIN MOTOR 0.2 Kw x 8 P
DUAL	SPEED 20.0 / 10.0 M/MIN	
	MOTOR 0.4/0.21Kw x 4/8 P	
POWER SUPPLY	3Ø, 220~575V, 60HZ 1Ø, 110V~230V, 60HZ	
CONTROL VOLTAGE	1Ø, 48V, 110V, 60HZ	
OPERATING METHOD	PUSH BUTTON TYPE	
LOAD CHAIN SPEC.	Ø5.0 x 15P x 1 FALL	
WIDTH OF BEAM	75~125 mm	
RADIUS OF BEAM	MIN. 1500 mm	
RATING	30 MIN.	
NET WEIGHT	Max. 101KG	

DIMENSIONS

구분	양정(LIFT)		
	3M~5M	5M~11M	11M~18M
기종	525	595	641
C	525	595	641

NO.	DESCRIPTION	MATL.	SIZE	QTY	REMARKS
DESIGNED	DESIGNED	SCALE	DATE	DATE	DATE
2013.05.10	2013.05.10	1/1	2013.05.10		
SC1-500	SC1-500				
SC1-500H	SC1-500H				

SAMSUNG HOIST CO., LTD.  
주식회사 삼성호이스트

TITLE OF PROJECT 0.5 TON MOTOR TROLLEY TYPE  
ELEC. CHAIN HOIST GENERAL ASSEMBLY

SCT-500 / 500H